

Ceramic PTC Thermistor: PPL Series

Overload Protection



■ Features

1. RoHS compliant
2. PPD series are disc and PPL are leaded type
3. Voltage rating: 12V_{ac}~1000V_{ac}
4. Resistance range: 0.3Ω~10KΩ
5. Stable over a long time
6. Operating temperature range: 0 ~ +60°C (V=V_{max})
-25 ~ +125°C (V=0)
7. Agency Recognition: UL/cUL, CQC and TUV
UL/cUL File No.: E138827
CQC File No.: CQC03001008123~124
TUV File No.: R50135521, R50143310, R50171789, R50135484

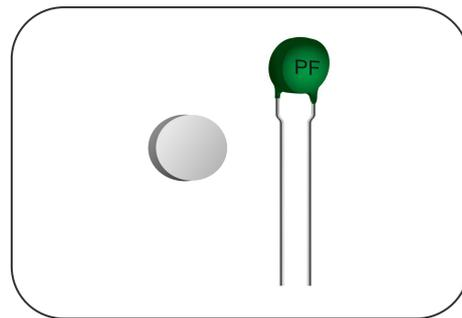

■ Recommended Applications

1. Home appliance
2. Electrical equipment (Electrical machinery, transformer, electric meter)

■ Part Number Code

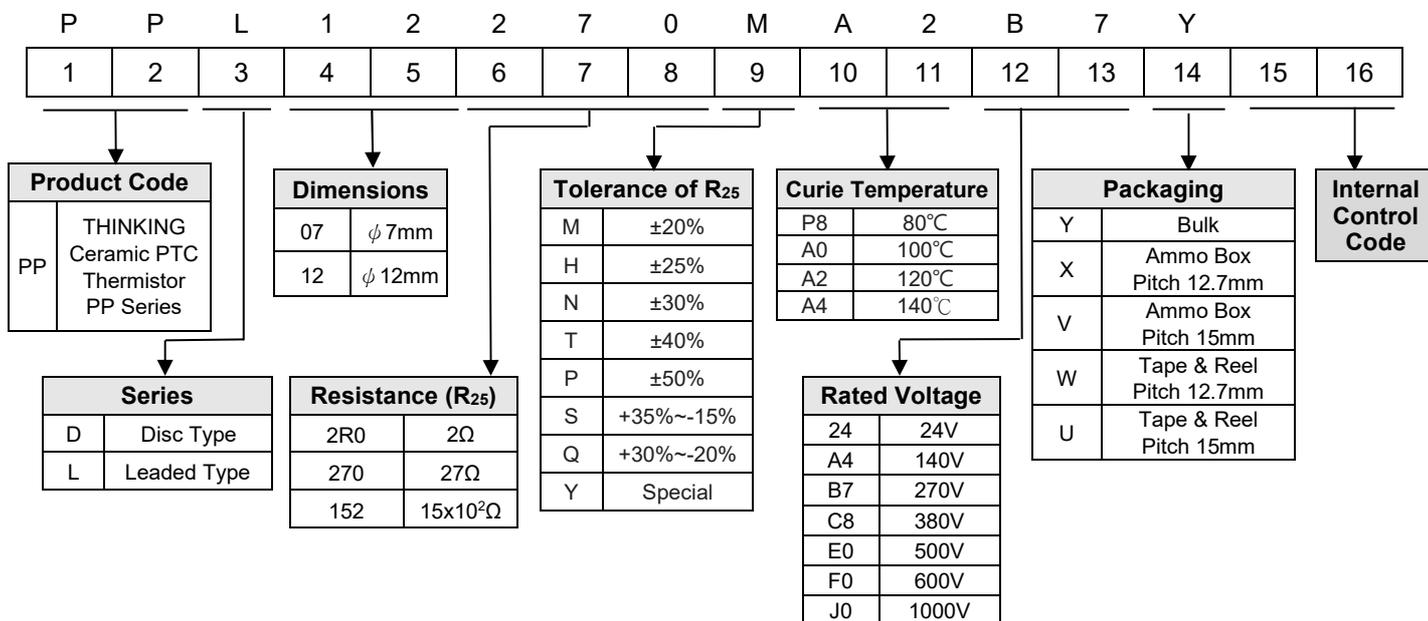

Ceramic PTC Thermistor: PPL Series

Overload Protection



■ Dimensions

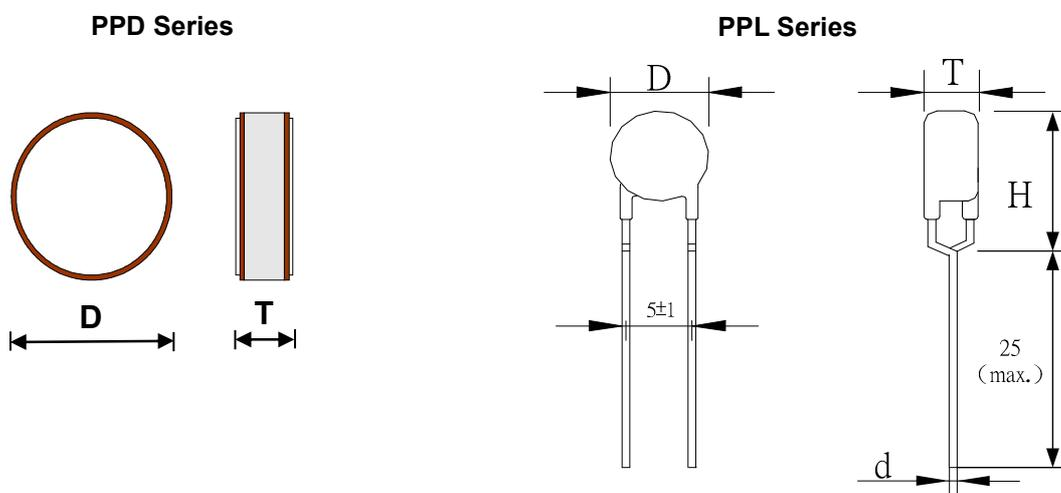

(Unit: mm)

■ Characteristics

PPD Series

Part No.	Curie Temperature	Zero-power Resistance at 25°C	Non-operating Current at 25°C	Trip Current at 25°C	Rated Voltage	Max. Current	Dimensions		Safety Approvals			
	T _c (°C)	R ₂₅ (Ω)	I _N (mA)	I _T (mA)	V _R (V _{ac})	I _{max} (A)	D(mm)	T(mm)	UL	cUL	CQC	TUV
PPD08650□A2B3	120±10	65	55	110	230	1	8.0±0.3	2.5±0.2	√	√		√
PPD08250□A3B3	130±10	25	125	250	230	1	8.0±0.3	2.5±0.2	√	√		√
PPD08650□A3B3		65	55	130	230	2	8.0±0.3	2.5±0.2	√	√		√
PPD05500□A3B3		50	50	130	230	1.2	5.0±0.3	2.5±0.2	√	√		√
PPD06350□A3B3		35	80	180	230	1	6.0±0.3	2.5±0.2	√	√		√

Note: □ is tolerance of R₂₅

PPL Series

24V_{ac} / 80°C

Part No.	Curie Temperature	Zero-power Resistance at 25°C	Non-operating Current at 25°C	Trip Current at 25°C	Rated Voltage	Max. Current	Dimensions				Safety Approvals			
	T _c (°C)	R ₂₅ (Ω)	I _N (mA)	I _T (mA)	V _R (V _{ac})	I _{max} (A)	D (mm)	T (mm)	d±0.02 (mm)	H _{max} (mm)	UL	cUL	CQC	TUV
PPL07100□P824	80±10	10	80	330	24	2.0	6.5-9.0	1.5-3.5	0.6	12.5	√	√	√	√

24V_{ac} / 120°C

Part No.	Curie Temperature	Zero-power Resistance at 25°C	Non-operating Current at 25°C	Trip Current at 25°C	Rated Voltage	Max. Current	Dimensions				Safety Approvals			
	T _c (°C)	R ₂₅ (Ω)	I _N (mA)	I _T (mA)	V _R (V _{ac})	I _{max} (A)	D (mm)	T (mm)	d±0.02 (mm)	H _{max} (mm)	UL	cUL	CQC	TUV
PPL03130□A224	120±10	13	120	240	24	0.7	2.5-4.0	1.5-3.5	0.5	8.5	√	√		√

Note: □ is tolerance of R₂₅

Ceramic PTC Thermistor: PPL Series

Overload Protection



24V_{ac} / 140°C

Part No.	Curie Temperature	Zero-power Resistance at 25°C	Non-operating Current at 25°C	Trip Current at 25°C	Rated Voltage	Max. Current	Dimensions				Safety Approvals			
	T _c (°C)						R ₂₅ (Ω)	I _N (mA)	I _T (mA)	V _R (V _{ac})	I _{max} (A)	D (mm)	T (mm)	d±0.02 (mm)
PPL056R0□A424	140±10	6.0	270	540	24	2.5	4.5-7.0	2.0-5.0	0.6	10.5	√	√		√
PPL05130□A424		13	180	360	24	1.7	4.5-7.0	2.0-5.0	0.6	10.5	√	√		√
PPL073R0□A424		3.0	410	820	24	4.5	6.5-9.0	2.0-5.0	0.6	12.5	√	√		√
PPL075R0□A424		5.0	320	640	24	3.5	6.5-9.0	2.0-5.0	0.6	12.5	√	√		√
PPL121R1□A424		1.1	830	1660	24	10.0	11.5-14.0	2.0-5.0	0.6	17.5	√	√		√

42V_{ac} / 80°C

Part No.	Curie Temperature	Zero-power Resistance at 25°C	Non-operating Current at 25°C	Trip Current at 25°C	Rated Voltage	Max. Current	Dimensions				Safety Approvals			
	T _c (°C)						R ₂₅ (Ω)	I _N (mA)	I _T (mA)	V _R (V _{ac})	I _{max} (A)	D (mm)	T (mm)	d±0.02 (mm)
PPL06220□P842	80±10	22	45	220	42	1.1	5.5-8.0	2.0-4.0	0.6	11.5	√	√	√	√
PPL06330□P842		33	40	180	42	0.9	5.5-8.0	2.0-4.0	0.6	11.5	√	√	√	√
PPL06470□P842		47	35	150	42	0.7	5.5-8.0	2.0-4.0	0.6	11.5	√	√	√	√
PPL06560□P842		56	30	140	42	0.7	5.5-8.0	2.0-4.0	0.6	11.5	√	√	√	√

48V_{ac} / 120°C

Part No.	Curie Temperature	Zero-power Resistance at 25°C	Non-operating Current at 25°C	Trip Current at 25°C	Rated Voltage	Max. Current	Dimensions				Safety Approvals			
	T _c (°C)						R ₂₅ (Ω)	I _N (mA)	I _T (mA)	V _R (V _{ac})	I _{max} (A)	D (mm)	T (mm)	d±0.02 (mm)
PPL04420□A248	120±10	42	105	210	48	0.75	3.5-6.5	2.0-5.0	0.6	10.5	√	√		√
PPL04600□A248		60	90	180	48	0.6	3.5-6.5	2.0-5.0	0.6	10.5	√	√		√
PPL04900□A248		90	70	140	48	0.46	3.5-6.5	2.0-5.0	0.6	10.5	√	√		√
PPL06220□A248		22	155	310	48	1.3	5.5-8.0	2.0-5.0	0.6	11.5	√	√		√
PPL06320□A248		32	130	260	48	0.95	5.5-8.0	2.0-5.0	0.6	11.5	√	√		√
PPL08180□A248		18	195	390	48	1.6	7.5-10.0	2.0-5.0	0.6	13.5	√	√		√
PPL10120□A248		12	230	460	48	2.2	9.5-12.0	2.0-5.0	0.6	15.5	√	√		√
PPL126R5□A248		6.5	350	700	48	4.0	11.5-14.0	2.0-5.0	0.6	17.5	√	√		√
PPL129R0□A248		9.0	285	570	48	2.9	11.5-14.0	2.0-5.0	0.6	17.5	√	√		√
PPL134R3□A248		4.3	425	850	48	6.3	12.5-15.0	2.0-5.0	0.6	18.5	√	√		√
PPL162R6□A248		2.6	605	1210	48	12	15.0-17.5	2.0-5.0	0.6	21.5	√	√		√
PPL163R8□A248		3.8	505	1010	48	7.3	15.0-17.5	2.0-5.0	0.6	21.5	√	√		√
PPL201R6□A248		1.6	870	1750	48	18	19.0-22.0	2.0-5.0	0.6	25.5	√	√		√
PPL202R2□A248		2.2	725	1450	48	14	19.0-22.0	2.0-5.0	0.6	25.5	√	√		√

Note: □ is tolerance of R₂₅

Ceramic PTC Thermistor: PPL Series

Overload Protection



48V_{ac} / 140°C

Part No.	Curie Temperature	Zero-power Resistance at 25°C	Non-operating Current at 25°C	Trip Current at 25°C	Rated Voltage	Max. Current	Dimensions				Safety Approvals			
	T _c (°C)	R ₂₅ (Ω)	I _N (mA)	I _T (mA)	V _R (V _{ac})	I _{max} (A)	D (mm)	T (mm)	d±0.02 (mm)	H _{max} (mm)	UL	cUL	CQC	TUV
PPL05500□A448	140±10	50	94	188	48	0.8	4.5-7.0	2.0-5.0	0.6	10.5	√	√		√

63V_{ac} / 120°C

Part No.	Curie Temperature	Zero-power Resistance at 25°C	Non-operating Current at 25°C	Trip Current at 25°C	Rated Voltage	Max. Current	Dimensions				Safety Approvals			
	T _c (°C)	R ₂₅ (Ω)	I _N (mA)	I _T (mA)	V _R (V _{ac})	I _{max} (A)	D (mm)	T (mm)	d±0.02 (mm)	H _{max} (mm)	UL	cUL	CQC	TUV
PPL03510□A263	120±10	51	55	165	63	0.7	2.5-5.0	2.0-4.0	0.5	8.5	√	√	√	√
PPL05240□A263		24	90	270	63	1.0	4.5-7.0	2.0-4.0	0.6	10.5	√	√	√	√
PPL089R1□A263		9.1	160	480	63	3.0	7.5-10.0	2.0-4.0	0.6	13.5	√	√	√	√
PPL113R6□A263		3.6	320	960	63	5.0	11.0-13.5	2.0-4.0	0.6	16.5	√	√	√	√
PPL152R4□A263		2.4	460	1400	63	7.5	14.0-17.5	2.0-4.0	0.6	21.5	√	√	√	√
PPL201R7□A263		1.7	700	1400	63	10	19.0-22.0	2.0-5.0	0.6	25.5	√	√		√

110V_{ac} / 120°C

Part No.	Curie Temperature	Zero-power Resistance at 25°C	Non-operating Current at 25°C	Trip Current at 25°C	Rated Voltage	Max. Current	Dimensions				Safety Approvals			
	T _c (°C)	R ₂₅ (Ω)	I _N (mA)	I _T (mA)	V _R (V _{ac})	I _{max} (A)	D (mm)	T (mm)	d±0.02 (mm)	H _{max} (mm)	UL	cUL	CQC	TUV
PPL09160□A2A1	120±10	16	150	450	110	1.5	8.5-11.0	2.0-5.0	0.6	14.5	√	√		√
PPL126R8□A2A1		6.8	290	660	110	1.0	11.5-14.0	2.0-4.5	0.6	17.5	√	√		√
PPL12100□A2A1		10	220	500	110	1.0	11.5-14.0	2.0-4.5	0.6	17.5	√	√		√
PPL164R7□A2A1		4.7	390	900	110	2.0	15.0-17.5	2.0-5.0	0.6	21.5	√	√		√

110V_{ac} / 140°C

Part No.	Curie Temperature	Zero-power Resistance at 25°C	Non-operating Current at 25°C	Trip Current at 25°C	Rated Voltage	Max. Current	Dimensions				Safety Approvals			
	T _c (°C)	R ₂₅ (Ω)	I _N (mA)	I _T (mA)	V _R (V _{ac})	I _{max} (A)	D (mm)	T (mm)	d±0.02 (mm)	H _{max} (mm)	UL	cUL	CQC	TUV
PPL05400□A4A1	140±10	40	110	220	110	0.5	4.5-7.0	3.0-5.0	0.6	10.5	√	√		√
PPL05550□A4A1		55	93	186	110	0.45	4.5-7.0	3.0-5.0	0.6	10.5	√	√		√
PPL05121□A4A1		120	65	130	110	0.3	4.5-7.0	3.0-5.0	0.6	10.5	√	√		√
PPL05241□A4A1		240	47	94	110	0.2	4.5-7.0	3.0-5.0	0.6	10.5	√	√		√
PPL088R0□A4A1		8.0	270	540	110	2.2	7.5-10.0	3.0-5.0	0.6	13.5	√	√		√
PPL089R4□A4A1		9.4	250	500	110	2.0	7.5-10.0	3.0-5.0	0.6	13.5	√	√		√
PPL105R3□A4A1		5.3	360	720	110	3.5	9.5-12.0	3.0-5.0	0.6	15.5	√	√		√
PPL106R7□A4A1		6.7	320	640	110	3.0	9.5-12.0	3.0-5.0	0.6	15.5	√	√		√
PPL123R8□A4A1		3.8	450	900	110	5.0	11.5-14.0	3.0-5.0	0.6	17.5	√	√		√
PPL124R6□A4A1		4.6	410	820	110	4.5	11.5-14.0	3.0-5.0	0.6	17.5	√	√		√

Note: □ is tolerance of R₂₅

Ceramic PTC Thermistor: PPL Series

Overload Protection



220V_{ac} / 80°C

Part No.	Curie Temperature	Zero-power Resistance at 25°C	Non-operating Current at 25°C	Trip Current at 25°C	Rated Voltage	Max. Current	Dimensions				Safety Approvals			
	T _c (°C)						R ₂₅ (Ω)	I _N (mA)	I _T (mA)	V _R (V _{ac})	I _{max} (A)	D (mm)	T (mm)	d±0.02 (mm)
PPL03151□P8B2	80±10	150	15	60	220	0.3	2.5-5.0	3.0-5.0	0.5	8.5	√	√	√	√
PPL03301□P8B2		300	10	35	220	0.2	2.5-5.0	3.0-5.0	0.5	8.5	√	√		√
PPL03601□P8B2		600	18	36	220	0.2	2.5-5.0	3.0-5.0	0.5	8.5	√	√		√
PPL04302□P8B2		3000	5	10	220	0.2	4.0-6.5	3.0-5.0	0.6	10.5	√	√		√
PPL05450□P8B2		45	40	150	220	0.5	4.5-7.0	3.0-5.0	0.6	10.5	√	√		√
PPL05680□P8B2		68	35	110	220	0.5	4.5-7.0	3.0-5.0	0.6	10.5	√	√	√	√
PPL05301□P8B2		300	15	40	220	0.1	4.5-7.0	3.0-5.0	0.6	10.5	√	√		√
PPL05331□P8B2		330	12	36	220	0.3	4.5-7.0	3.0-5.0	0.6	10.5	√	√		√
PPL06251□P8B2		250	15	50	220	0.6	5.5-8.0	3.0-5.0	0.6	11.5	√	√		√
PPL07180□P8B2		18	70	200	220	0.8	6.5-9.0	3.0-5.0	0.6	12.5	√	√		√
PPL07250□P8B2		25	60	130	220	1.0	6.5-9.0	3.0-5.0	0.6	12.5	√	√		√
PPL07360□P8B2		36	45	180	220	0.7	6.5-9.0	3.0-5.0	0.6	12.5	√	√	√	√
PPL08220□P8B2		22	65	195	220	1.2	7.5-10.0	3.0-5.0	0.6	13.5	√	√	√	√
PPL08101□P8B2		100	30	90	220	0.5	7.5-10.0	3.0-5.0	0.6	13.5	√	√		√
PPL08152□P8B2		1500	7	14	220	0.1	7.5-10.0	3.0-5.0	0.6	13.5	√	√		√
PPL09150□P8B2		15	90	270	220	1.5	8.5-11.0	3.0-5.0	0.6	14.5	√	√	√	√
PPL09180□P8B2		18	75	225	220	1.3	8.5-11.0	3.0-5.0	0.6	14.5	√	√	√	√
PPL11100□P8B2		10	120	360	220	2.3	11.0-13.5	3.0-5.0	0.6	16.5	√	√	√	√
PPL155R6□P8B2		5.6	180	540	220	4.5	14.0-17.5	3.0-5.0	0.6	21.5	√	√	√	√
PPL203R9□P8B2		3.9	240	720	220	7.0	19.0-22.0	3-6.0	0.6	26.0	√	√	√	√
PPL242R7□P8B2		2.7	350	1050	220	9.5	24.0-27.0	3-6.0	0.8	30.5				

220V_{ac} / 120°C

Part No.	Curie Temperature	Zero-power Resistance at 25°C	Non-operating Current at 25°C	Trip Current at 25°C	Rated Voltage	Max. Current	Dimensions				Safety Approvals			
	T _c (°C)						R ₂₅ (Ω)	I _N (mA)	I _T (mA)	V _R (V _{ac})	I _{max} (A)	D (mm)	T (mm)	d±0.02 (mm)
PPL03151□A2B2	120±10	150	30	90	220	0.3	2.5-5.0	3.0-5.0	0.5	8.5	√	√	√	√
PPL03102□A2B2		1000	13	27	220	0.2	2.5-5.0	3.0-5.0	0.5	8.5	√	√		√
PPL03302□A2B2		3000	9	18	220	0.2	2.5-5.0	3.0-5.0	0.5	8.5	√	√		√
PPL04381□A2B2		380	35	70	220	0.25	4.0-6.5	3.0-5.0	0.6	10.5	√	√		√
PPL04561□A2B2		560	30	60	220	0.2	4.0-6.5	3.0-5.0	0.6	10.5	√	√		√
PPL04751□A2B2		750	15	45	220	0.3	4.0-6.5	3.0-5.0	0.6	10.5	√	√		√
PPL04851□A2B2		850	25	50	220	0.16	4.0-6.5	3.0-5.0	0.6	10.5	√	√		√
PPL04122□A2B2		1200	20	40	220	0.13	4.0-6.5	3.0-5.0	0.6	10.5	√	√		√
PPL04192□A2B2		1900	15	30	220	0.11	4.0-6.5	3.0-5.0	0.6	10.5	√	√		√
PPL05750□A2B2		75	50	150	220	0.5	4.5-7.0	3.0-5.0	0.6	10.5	√	√	√	√
PPL05151□A2B2		150	35	70	220	0.2	4.5-7.0	3.0-5.0	0.6	10.5	√	√		√
PPL05181□A2B2		180	29	70	220	0.3	4.5-7.0	3.0-5.0	0.6	10.5	√	√		√

Note: □ is tolerance of R₂₅

Ceramic PTC Thermistor: PPL Series

Overload Protection



220V_{ac} / 120°C

Part No.	Curie Temperature	Zero-power Resistance at 25°C	Non-operating Current at 25°C	Trip Current at 25°C	Rated Voltage	Max. Current	Dimensions				Safety Approvals			
	T _c (°C)						R ₂₅ (Ω)	I _N (mA)	I _T (mA)	V _R (V _{ac})	I _{max} (A)	D (mm)	T (mm)	d±0.02 (mm)
PPL06450□A2B2	120±10	45	80	160	220	0.7	5.5-8.0	3.0-5.0	0.6	11.5	√	√		√
PPL06720□A2B2		72	70	180	220	0.6	5.5-8.0	3.0-5.0	0.6	11.5	√	√		√
PPL06121□A2B2		120	35	100	220	0.4	5.5-8.0	3.0-5.0	0.6	11.5	√	√	√	√
PPL06201□A2B2		200	50	100	220	0.35	5.5-8.0	3.0-5.0	0.6	11.5	√	√		√
PPL06281□A2B2		280	45	90	220	0.29	5.5-8.0	3.0-5.0	0.6	11.5	√	√		√
PPL06301□A2B2		300	33	66	220	0.2	5.5-8.0	3.0-5.0	0.6	11.5	√	√		√
PPL07250□A2B2		25	125	250	220	1.0	6.5-9.0	3.0-5.0	0.6	11.5	√	√		√
PPL07560□A2B2		56	60	200	220	0.8	6.5-9.0	3.0-5.0	0.6	12.5	√	√		√
PPL07820□A2B2		82	60	160	220	0.5	6.5-9.0	3.0-5.0	0.6	12.5	√	√		√
PPL07401□A2B2		400	22	55	220	0.4	6.5-9.0	3.0-5.0	0.6	12.5	√	√		√
PPL08150□A2B2		15	150	300	220	1.0	7.5-10.0	3.0-5.0	0.6	13.5	√	√		√
PPL08240□A2B2		24	100	300	220	1.1	7.5-10.0	3.0-5.0	0.6	13.5	√	√		√
PPL08360□A2B2		36	85	250	220	1.0	7.5-10.0	3.0-5.0	0.6	13.5	√	√	√	√
PPL08500□A2B2		50	105	210	220	0.73	7.5-10.0	3.0-5.0	0.6	13.5	√	√		√
PPL08510□A2B2		51	65	195	220	1.0	7.5-10.0	3.0-5.0	0.6	13.5	√	√	√	√
PPL08620□A2B2		62	55	165	220	1.0	7.5-10.0	3.0-5.0	0.6	13.5	√	√	√	√
PPL08720□A2B2		72	90	180	220	0.6	7.5-10.0	3.0-5.0	0.6	13.5	√	√		√
PPL09160□A2B2		16	150	450	220	1.5	8.5-11.0	3.0-5.0	0.6	14.5	√	√	√	√
PPL10150□A2B2		15	140	280	220	1.5	9.5-12.0	3.0-5.0	0.6	15.5	√	√		√
PPL10260□A2B2		26	155	310	220	1.1	9.5-12.0	3.0-5.0	0.6	15.5	√	√		√
PPL11110□A2B2		11	200	600	220	2.2	11.0-13.5	3.0-5.0	0.6	16.5	√	√	√	√
PPL12100□A2B2		10	230	650	220	2.3	11.0-14.0	3.0-5.0	0.6	17.5	√	√	√	√
PPL12140□A2B2		14	230	460	220	1.7	11.0-14.0	3.0-5.0	0.6	17.5	√	√		√
PPL12200□A2B2		20	195	390	220	1.3	11.0-14.0	3.0-5.0	0.6	17.5	√	√		√
PPL14180□A2B2		18	180	450	220	1.8	13.5-16.0	3.0-5.0	0.6	19.5	√	√		√
PPL14800□A2B2		80	80	240	220	1.5	13.5-16.0	3.0-5.0	0.6	19.5	√	√		√
PPL156R2□A2B2		6.2	320	960	220	4.0	14.0-17.5	3.0-5.0	0.6	21.5	√	√	√	√
PPL168R0□A2B2		8.0	350	700	220	2.5	14.0-17.5	3.0-6.0	0.6	21.5	√	√		√
PPL203R6□A2B2		3.6	460	1380	220	7.0	19.0-22.0	3.0-6.0	0.6	26.0	√	√	√	√
PPL205R0□A2B2		5.0	505	1010	220	3.6	19.0-22.0	3.0-6.0	0.6	26.0	√	√		√
PPL207R0□A2B2	7.0	425	850	220	3.0	19.0-22.0	3.0-6.0	0.6	26.0	√	√		√	
PPL242R4□A2B2	2.4	660	1980	220	10.5	24.0-27.0	3.0-6.0	0.8	30.5	√	√		√	

220V_{ac} / 130°C

Part No.	Curie Temperature	Zero-power Resistance at 25°C	Non-operating Current at 25°C	Trip Current at 25°C	Rated Voltage	Max. Current	Dimensions				Safety Approvals			
	T _c (°C)						R ₂₅ (Ω)	I _N (mA)	I _T (mA)	V _R (V _{ac})	I _{max} (A)	D (mm)	T (mm)	d±0.02 (mm)
PPL04161□A3B2	130±10	160	55	90	220	0.2	4.0-6.5	3.0-5.0	0.6	10.5	√	√		√
PPL08250□A3B2		25	140	230	220	1.0	7.5-10.0	3.0-5.0	0.6	13.5	√	√		√
PPL10130□A3B2		13	200	320	220	1.5	9.5-12.0	3.0-5.0	0.6	15.5	√	√		√
PPL129R0□A3B2		9.0	330	500	220	2.2	11.0-14.0	3.0-5.0	0.6	17.5	√	√		√

Note: □ is tolerance of R₂₅

Ceramic PTC Thermistor: PPL Series

Overload Protection



220V_{ac} / 140°C

Part No.	Curie Temperature	Zero-power Resistance at 25°C	Non-operating Current at 25°C	Trip Current at 25°C	Rated Voltage	Max. Current	Dimensions				Safety Approvals			
	T _c (°C)						R ₂₅ (Ω)	I _N (mA)	I _T (mA)	V _R (V _{ac})	I _{max} (A)	D (mm)	T (mm)	d±0.02 (mm)
PPL04302□A4B2	140±10	3000	11	17	220	0.08	4-6.5.0	3.0-5.0	0.6	10.5	√	√		√
PPL05121□A4B2		120	63	126	220	0.45	4.5-7.0	3.0-5.0	0.6	10.5	√	√		√
PPL05261□A4B2		260	39	78	220	0.3	4.5-7.0	3.0-5.0	0.6	10.5	√	√		√
PPL05501□A4B2		500	28	56	220	0.2	4.5-7.0	3.0-5.0	0.6	10.5	√	√		√
PPL05122□A4B2		1200	19	38	220	0.14	4.5-7.0	3.0-5.0	0.6	10.5	√	√		√
PPL05192□A4B2		1900	15	30	220	0.11	4.5-7.0	3.0-5.0	0.6	10.5	√	√		√
PPL07290□A4B2		29	140	280	220	0.8	6.5-9.0	3.0-5.0	0.6	12.5	√	√		√
PPL07480□A4B2		48	110	220	220	0.65	6.5-9.0	3.0-5.0	0.6	12.5	√	√		√
PPL08180□A4B2		18	190	380	220	1.0	7.5-10.0	3.0-5.0	0.6	13.5	√	√		√
PPL08220□A4B2		22	170	340	220	0.9	7.5-10.0	3.0-5.0	0.6	13.5	√	√		√
PPL08240□A4B2		24	110	330	220	1.0	7.5-10.0	3.0-5.0	0.6	13.5	√	√		√
PPL09160□A4B2		16	150	450	220	1.5	8.5-11.0	3.0-5.0	0.6	14.5	√	√		√
PPL10120□A4B2		12	250	500	220	1.5	9.5-12.0	3.0-5.0	0.6	15.5	√	√		√
PPL10170□A4B2		17	210	420	220	1.3	9.5-12.0	3.0-5.0	0.6	15.5	√	√		√
PPL164R4□A4B2		4.4	490	980	220	3.5	14.0-17.5	3.0-6.0	0.6	21.5	√	√		√
PPL166R6□A4B2		6.6	400	800	220	3.0	14.0-17.5	3.0-6.0	0.6	21.5	√	√		√

250V_{ac} / 100°C

Part No.	Curie Temperature	Zero-power Resistance at 25°C	Non-operating Current at 25°C	Trip Current at 25°C	Rated Voltage	Max. Current	Dimensions				Safety Approvals			
	T _c (°C)						R ₂₅ (Ω)	I _N (mA)	I _T (mA)	V _R (V _{ac})	I _{max} (A)	D (mm)	T (mm)	d±0.02 (mm)
PPL07220□A0B5	100±10	22	100	260	250	0.5	6.5-9.0	3.0-6.0	0.6	12.5	√	√		√

270V_{ac} / 120°C

Part No.	Curie Temperature	Zero-power Resistance at 25°C	Non-operating Current at 25°C	Trip Current at 25°C	Rated Voltage	Max. Current	Dimensions				Safety Approvals			
	T _c (°C)						R ₂₅ (Ω)	I _N (mA)	I _T (mA)	V _R (V _{ac})	I _{max} (A)	D (mm)	T (mm)	d±0.02 (mm)
PPL05102□A2B7	120±10	1000	18	36	270	0.1	4.5-7.0	3.0-5.0	0.6	10.5	√	√		√
PPL05332□A2B7		3300	8	16	270	0.12	4.5-7.0	3.0-5.0	0.6	10.5	√	√		√
PPL08390□A2B7		39	75	240	270	1.2	7.5-10.0	3.0-5.0	0.6	13.5	√	√		√
PPL10390□A2B7		39	100	250	270	1.2	9.5-12.0	3.0-5.0	0.6	15.5	√	√		√
PPL12270□A2B7		27	120	350	270	1.5	11.0-14.0	3.0-5.0	0.6	17.5	√	√		√
PPL16220□A2B7		22	230	500	270	8.0	14.0-18.0	3.5-7.0	0.6	21.5	√	√		√
PPL16500□A2B7		50	160	320	270	4.0	14.0-18.0	3.5-7.0	0.6	21.5	√	√		√

Note: □ is tolerance of R₂₅

Ceramic PTC Thermistor: PPL Series

Overload Protection



300V_{ac} / 120°C

Part No.	Curie Temperature	Zero-power Resistance at 25°C	Non-operating Current at 25°C	Trip Current at 25°C	Rated Voltage	Max. Current	Dimensions				Safety Approvals			
	T _c (°C)	R ₂₅ (Ω)	I _N (mA)	I _T (mA)	V _R (V _{ac})	I _{max} (A)	D (mm)	T (mm)	d±0.02 (mm)	H _{max} (mm)	UL	cUL	CQC	TUV
PPL10820□A2C0	120±10	82	80	250	300	0.5	9.5-12.0	3.0-5.5	0.6	15.5	√	√		√
PPL10151□A2C0		150	60	150	300	0.3	9.5-12.0	3.0-5.5	0.6	15.5	√	√		√
PPL10351□A2C0		350	35	100	300	0.3	9.5-12.0	3.0-5.5	0.6	15.5	√	√		√

380V_{ac} / 120°C

Part No.	Curie Temperature	Zero-power Resistance at 25°C	Non-operating Current at 25°C	Trip Current at 25°C	Rated Voltage	Max. Current	Dimensions				Safety Approvals			
	T _c (°C)	R ₂₅ (Ω)	I _N (mA)	I _T (mA)	V _R (V _{ac})	I _{max} (A)	D (mm)	T (mm)	d±0.02 (mm)	H _{max} (mm)	UL	cUL	CQC	TUV
PPL05601□A2C8	120±10	600	21	39	380	0.2	4.5-7.0	3.0-5.0	0.6	10.5	√	√		√
PPL07131□A2C8		130	45	90	380	1.0	6.5-9.0	4.0-7.0	0.6	12.5	√	√		√
PPL08700□A2C8		70	64	127	380	1.4	7.5-10.0	4.5-7.0	0.6	13.5	√	√		√
PPL08121□A2C8		120	49	100	380	1.4	7.5-10.0	4.5-7.0	0.6	13.5	√	√		√
PPL08151□A2C8		150	43	86	380	1.4	7.5-10.0	4.5-7.0	0.6	13.5	√	√		√
PPL11250□A2C8		25	123	245	380	2.0	10.5-13.0	4.5-7.0	0.6	16.5	√	√		√
PPL11500□A2C8		50	87	173	380	2.0	10.5-13.0	4.5-7.0	0.6	16.5	√	√		√
PPL11800□A2C8		80	69	137	380	2.0	10.5-13.0	4.5-7.0	0.6	16.5	√	√		√
PPL11121□A2C8		120	56	112	380	2.0	10.5-13.0	4.5-7.0	0.6	16.5	√	√		√
PPL11151□A2C8		150	50	100	380	2.0	10.5-13.0	4.5-7.0	0.6	16.5	√	√		√

400V_{ac} / 120°C

Part No.	Curie Temperature	Zero-power Resistance at 25°C	Non-operating Current at 25°C	Trip Current at 25°C	Rated Voltage	Max. Current	Dimensions				Safety Approvals			
	T _c (°C)	R ₂₅ (Ω)	I _N (mA)	I _T (mA)	V _R (V _{ac})	I _{max} (A)	D (mm)	T (mm)	d±0.02 (mm)	H _{max} (mm)	UL	cUL	CQC	TUV
PPL05251□A2D0	120±10	250	32	65	400	0.3	4.5-7.0	3.0-5.0	0.6	10.5	√	√		√
PPL05381□A2D0		380	30	56	400	0.3	4.5-7.0	3.0-5.0	0.6	10.5	√	√		√
PPL05561□A2D0		560	22	44	400	0.3	4.5-7.0	3.0-5.0	0.6	10.5	√	√		√
PPL05601□A2D0		600	18	38	400	0.3	4.5-7.0	3.0-5.0	0.6	10.5	√	√		√

500V_{ac} / 120°C

Part No.	Curie Temperature	Zero-power Resistance at 25°C	Non-operating Current at 25°C	Trip Current at 25°C	Rated Voltage	Max. Current	Dimensions				Safety Approvals			
	T _c (°C)	R ₂₅ (Ω)	I _N (mA)	I _T (mA)	V _R (V _{ac})	I _{max} (A)	D (mm)	T (mm)	d±0.02 (mm)	H _{max} (mm)	UL	cUL	CQC	TUV
PPL05122□A2E0	120±10	1200	15	30	500	0.1	4.5-7.0	3.0-5.5	0.6	10.5	√	√		√
PPL05152□A2E0		1500	12	24	500	0.1	4.5-7.0	3.0-5.5	0.6	10.5	√	√		√
PPL08501□A2E0		500	24	48	500	1.0	7.5-10.0	4.5-7.0	0.6	13.5	√	√		√
PPL08112□A2E0		1100	16	32	500	1.0	7.5-10.0	4.5-7.0	0.6	13.5	√	√		√
PPL11501□A2E0		500	28	55	500	1.4	10.5-13.0	4.5-7.0	0.6	17	√	√		√

Note: □ is tolerance of R₂₅

Ceramic PTC Thermistor: PPL Series

Overload Protection



600V_{ac} / 90°C

Part No.	Curie Temperature	Zero-power Resistance at 25°C	Non-operating Current at 25°C	Trip Current at 25°C	Rated Voltage	Max. Current	Dimensions				Safety Approvals			
	T _c (°C)						R ₂₅ (Ω)	I _N (mA)	I _T (mA)	V _R (V _{ac})	I _{max} (A)	D (mm)	T (mm)	d±0.02 (mm)
PPL05801□P9F0	90±10	800	18	36	600	0.3	4.5-7.0	3.0-5.5	0.6	10.5	√	√		√
PPL05102□P9F0		1000	15	30	600	0.3	4.5-7.0	3.0-5.5	0.6	10.5	√	√		√
PPL05132□P9F0		1300	13	26	600	0.3	4.5-7.0	3.0-5.5	0.6	10.5	√	√		√

600V_{ac} / 100°C

Part No.	Curie Temperature	Zero-power Resistance at 25°C	Non-operating Current at 25°C	Trip Current at 25°C	Rated Voltage	Max. Current	Dimensions				Safety Approvals			
	T _c (°C)						R ₂₅ (Ω)	I _N (mA)	I _T (mA)	V _R (V _{ac})	I _{max} (A)	D (mm)	T (mm)	d±0.02 (mm)
PPL05152□A0F0	100±10	1500	14	28	600	0.1	4.5-7.0	3.0-5.5	0.6	10.5	√	√		√
PPL05212□A0F0		2100	8	18	600	0.1	4.5-7.0	3.0-5.5	0.6	10.5	√	√		√
PPL05272□A0F0		2700	10	20	600	0.2	4.5-7.0	3.0-5.5	0.6	10.5	√	√		√
PPL06103□A0F0		10000	5	12	600	0.1	5.5-8.0	3.0-5.5	0.6	11.5	√	√		√
PPL07152□A0F0		1500	14	28	600	0.2	6.5-9.0	4.0-7.0	0.6	12.5	√	√		√

1000V_{ac} series

Part No.	Curie Temperature	Zero-power Resistance at 25°C	Non-operating Current at 25°C	Trip Current at 25°C	Rated Voltage	Max. Current	Dimensions				Safety Approvals			
	T _c (°C)						R ₂₅ (Ω)	I _N (mA)	I _T (mA)	V _R (V _{ac})	I _{max} (A)	D (mm)	T (mm)	d±0.02 (mm)
PPL08701□P8J0	80±10	700	\	\	1000	0.7	7.5-10.0	4.5-7.0	0.6	13.5	√			√
PPL08112□P8J0		1100	16	32	1000	0.7	7.5-10.0	4.5-7.0	0.6	13.5	√	√		√
PPL08202□P8J0		2000	\	\	1000	0.25	7.5-10.0	4.5-7.0	0.6	13.5	√	√		√
PPL07152□A0J0	100±10	1500	14	28	1000	0.2	6.5-9.0	4.5-7.0	0.6	12.5	√	√		√
PPL11752□A1J0	110±10	7500	8	17	1000	0.5	10.5-13.0	4.5-7.0	0.6	17.0	√	√		√

Note: □ is tolerance of R₂₅

Ceramic PTC Thermistor: PPL Series

Overload Protection



■ Soldering Recommendation

● Wave Flow Soldering Profile

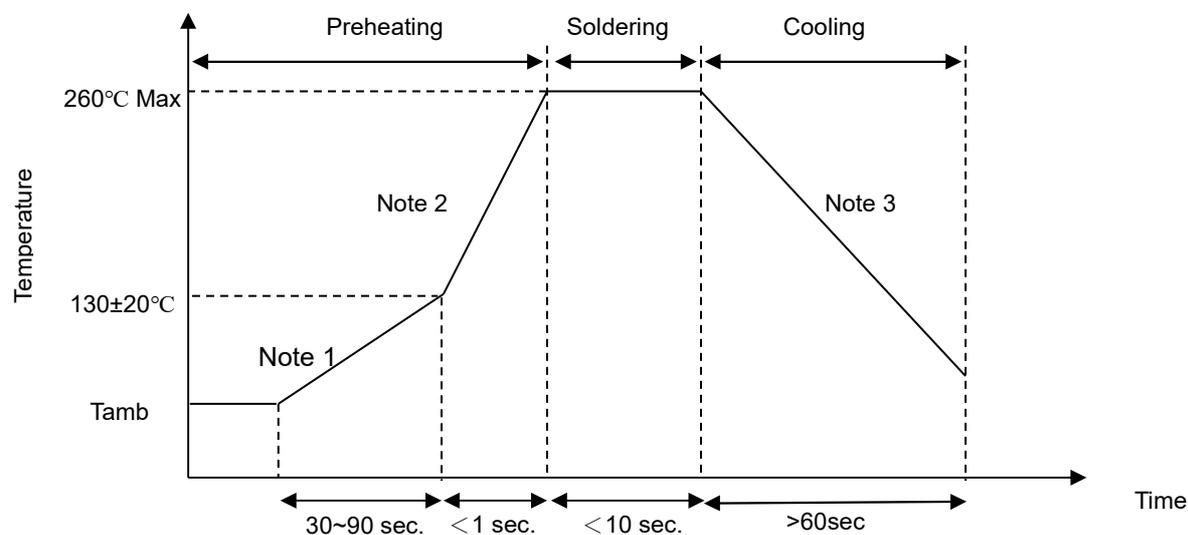

Note

1. 1~3°C/sec.
2. Approx. 200°C/sec
3. 5°C/sec. (Max)

● Recommended Reworking Conditions with Soldering Iron

Item	Conditions
Temperature of Soldering Iron-tip	360°C (max.)
Soldering Time	3 sec (max.)
Distance from Thermistor	2 mm (min.)

Ceramic PTC Thermistor: PPL Series

Overload Protection



■ Reliability Test

Item	Standard	Test conditions and methods	Specifications															
Robustness of Terminations *1	IEC 60738-1	Gradually apply the specified force and keep the unit fixed for 10±1 sec. <table border="1" style="margin-left: auto; margin-right: auto;"> <thead> <tr> <th>Terminal diameter (mm)</th> <th>Force T(N)</th> </tr> </thead> <tbody> <tr> <td>0.35<d≤0.5</td> <td>5.0</td> </tr> <tr> <td>0.5<d≤0.8</td> <td>10.0</td> </tr> <tr> <td>0.8<d≤1.25</td> <td>20.0</td> </tr> </tbody> </table>	Terminal diameter (mm)	Force T(N)	0.35<d≤0.5	5.0	0.5<d≤0.8	10.0	0.8<d≤1.25	20.0	$\Delta R_{25}/R_{25}$ ≤ 20% No visible damage							
Terminal diameter (mm)	Force T(N)																	
0.35<d≤0.5	5.0																	
0.5<d≤0.8	10.0																	
0.8<d≤1.25	20.0																	
Solderability*1	IEC 60738-1	245±3 °C, 2±0.5 sec	At least 95% of terminal electrode is covered by new solder															
Resistance to Soldering Heat *1	IEC 60738-1	260±3 °C, 10±1 sec	$\Delta R_{25}/R_{25}$ ≤ 20% No visible damage															
Vibration *1	IEC 60738-1	Frequency range:10~55Hz Amplitude: 0.75mm or 98m/s ² Direction: 3 mutually perpendicular directions Duration: 6hrs(3x2 hrs)	$\Delta R_{25}/R_{25}$ ≤ 20% No visible damage															
Shock *1	IEC 60738-1	Wave: half-sine ΔV: 1.0m/s Acceleration: 50 m/s ² Pulse time: 30ms	$\Delta R_{25}/R_{25}$ ≤ 20% No visible damage															
Rapid Change of Temperature	IEC 60738-1	The thermal shock conditions shown below shall be repeated 5 cycles. <table border="1" style="margin-left: auto; margin-right: auto;"> <thead> <tr> <th>Step</th> <th>Temperature (°C)</th> <th>Period (minutes)</th> </tr> </thead> <tbody> <tr> <td>1</td> <td>-40 ± 5</td> <td>30 ± 3</td> </tr> <tr> <td>2</td> <td>Room temperature</td> <td>5 ± 3</td> </tr> <tr> <td>3</td> <td>85 ± 5</td> <td>30 ± 3</td> </tr> <tr> <td>4</td> <td>Room temperature</td> <td>5 ± 3</td> </tr> </tbody> </table>	Step	Temperature (°C)	Period (minutes)	1	-40 ± 5	30 ± 3	2	Room temperature	5 ± 3	3	85 ± 5	30 ± 3	4	Room temperature	5 ± 3	$\Delta R_{25}/R_{25}$ ≤ 20% No visible damage
Step	Temperature (°C)	Period (minutes)																
1	-40 ± 5	30 ± 3																
2	Room temperature	5 ± 3																
3	85 ± 5	30 ± 3																
4	Room temperature	5 ± 3																
Climatic Sequence	IEC 60738-1	Dry heat: 125 °C for 16 hrs Damp heat first cycle: 40°C, 95% R.H ,cycle time: 24 hrs Cold: -40°C for 2 hrs Damp heat (cyclic), remaining cycles: 5 cycles Test according to IEC60068-2-30	$\Delta R_{25}/R_{25}$ ≤ 20% No visible damage															
Damp Heat, Steady State	IEC 60738-1	40±2°C, 90~95%RH, 1000±2hrs	$\Delta R_{25}/R_{25}$ ≤ 20% No visible damage															
Endurance at Maximum Operating Temperature and Maximum Voltage	IEC 60738-1	UCT=60°C, V _R , I _t ≤ I ≤ I _{max} , 1000±2hrs	$\Delta R_{25}/R_{25}$ ≤ 20% No visible damage															
Endurance at Maximum Voltage	IEC60738-1	25±5°C, V _R , I _t ≤ I ≤ I _{max} 1min. on and 5min. Off ×100cycles	$\Delta R_{25}/R_{25}$ ≤ 20% No visible damage															

Note: *1 Items are applicable for PPL series only.

Ceramic PTC Thermistor: PPL Series

Overload Protection



■ Packaging

● Taping Specification

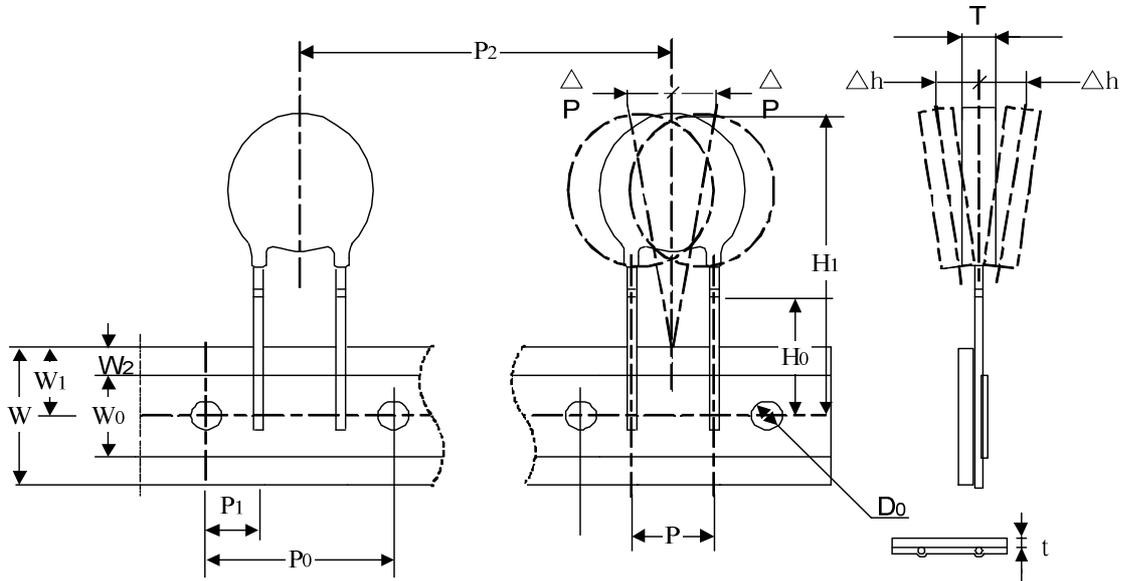

Figure A

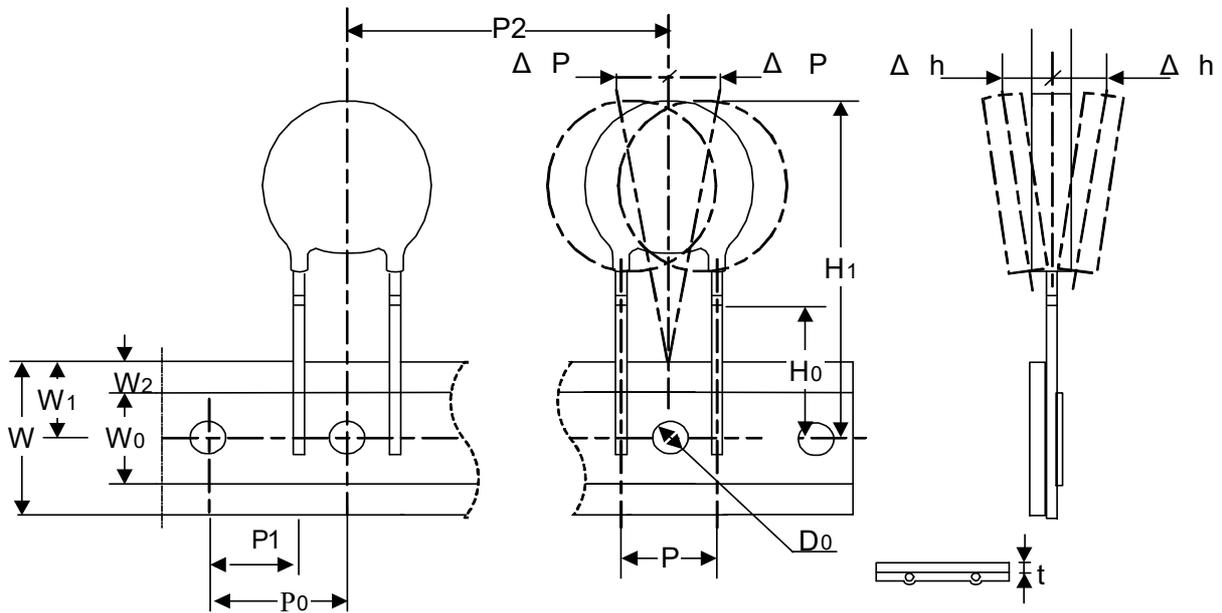

Figure B

Ceramic PTC Thermistor: PPL Series

Overload Protection



● Parameter List of Kinked Lead

Index	Parameter	Nominal dimensions					Tolerance
P	Lead spacing	2.5	5	7.5	5	7.5	±1
P ₀	Sprocket hole pitch	12.7			15.0		±0.3
P ₁	Ordinate to adjacent component lead	5.1	3.85	8.95	5.0	3.75	±1
P ₂ *1	Device pitch	12.7	12.7	25.4	15.0	30	±1
H ₀	Abscissa to plane (kinked lead)	16	16	16	16	16	±0.5
H ₁ *2	Abscissa to top	Refer to Table1: H _{1max} and P					
W	Carrier tape width	18	18	18	18	18	±1
W ₀	Hold-down tape width	12	12	12	12	12	±1.5
W ₁	Sprocket hole position	9	9	9	9	9	±1
W ₂	Top distance between tape edges	3	3	3	3	3	Max.
△ P	Body tape plane deviation	1	1	1	1	1	Max.
△ h	Body lateral deviation	2	2	2	2	2	Max.
D ₀	Sprocket hole diameter	4	4	4	4	4	±0.2
t	Tape thickness	0.6	0.6	0.6	0.6	0.6	±0.2
Figure		A	A	B	A	A	---

Table1: H_{1max} and P

Diameter of Disc		03	04	05	06	07	08	09	10	11	12	13	14	15	16	17	18	19	20	
P	P ₀ :12.7	12.7									25.4									
	P ₀ :15.0	15.0									30.0									
H _{1max}		25.0	26.0	27.0	28.0	29.0	30.0	31.0	32.0	33.5	34	35	36	37.5	38.0	39.0	40.0	41.0	42.0	

Ceramic PTC Thermistor: PPL Series

Overload Protection



Quantity

● Bulk Packing

Disc Size(mm)	Quantity (pcs/bag)
$\Phi \leq 10$	200
$10 < \Phi < 20$	100
$\Phi \geq 20$	50

● Reel Packing

Disc Size (mm)	Rated Voltage (V_R)	Quantity (pcs/reel)
$\Phi \leq 07$	$V_R \leq 270V_{ac}$	1,500
	$V_R > 270V_{ac}$	1,000
$07 < \Phi \leq 12$	$V_R \leq 270V_{ac}$	1,000
	$V_R > 270V_{ac}$	750
$12 < \Phi \leq 16$	$V_R \leq 270V_{ac}$	750
	$V_R > 270V_{ac}$	500
$\Phi > 16$	$V_R \leq 270V_{ac}$	500
	$V_R > 270V_{ac}$	250

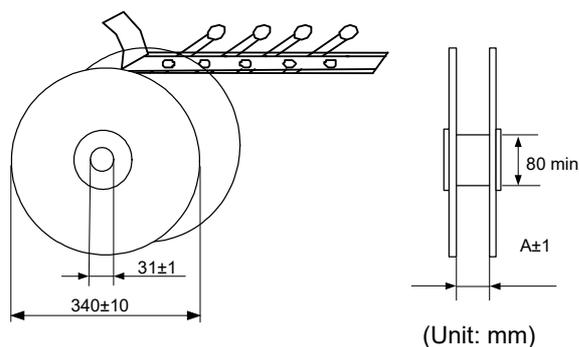

Disc Size	$\Phi < 16$	$\Phi \geq 16$
A	46	55

● Ammo Packing

Disc Size(mm)	Rated Voltage (V_R)	Quantity (pcs/box)
$\Phi \leq 07$	$V_R \leq 270V_{ac}$	1,000
	$V_R > 270V_{ac}$	750
$07 < \Phi \leq 12$	$V_R \leq 270V_{ac}$	750
	$V_R > 270V_{ac}$	500
$12 < \Phi \leq 16$	$V_R \leq 270V_{ac}$	500
	$V_R > 270V_{ac}$	250
$\Phi > 16$	---	250

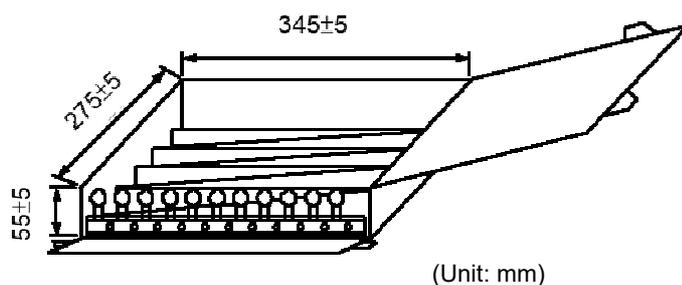

Warehouse Storage Conditions of Products

● Storage Conditions:

1. Storage Temperature: $-10^{\circ}\text{C} \sim +40^{\circ}\text{C}$
2. Relative Humidity: $\leq 75\% \text{RH}$
3. Keep away from corrosive atmosphere and sunlight.

● Period of Storage: 1 year

Ceramic PTC Thermistor: PPL Series

Overload Protection



■ Usage

Please keep products away from the conditions mentioned below to avoid their characteristic deterioration and failure.

1. Corrosive gas or deoxidizing gas (Cl₂, H₂S, NH₃, SO_x, NO_x etc.)
2. Place in a vacuum or put pressure
3. Salt water, oil, solvent and chemical liquid
4. Flammable gas
5. Place in splashed water, or high humidity and dewing place
6. Other places similar to any conditions mentioned above